

**Bulletin No. 012.5.Re.001A**

**SERVICE OF THE LAK-12 SAILPLANE  
AFTER 500 FLIGHT HOURS  
OR 5-YEAR OPERATION**

1995

## SERVICE AFTER 500 FLIGHT HOURS OR 5-YEAR OPERATION

The bulletin is for the LAK-12 sailplanes with the period of operation of 5 years and flight time of 500 hours.

It is required to accomplish service work after the 5-year operation or 500 flight hours.

The service work is carried out by the technical personnel having the experience in the field of maintenance and repairing plastic sailplanes.

### COMPLETE THE FOLLOWING ACTION:

1. Measure backlashes of control surfaces by rear edges (when the control stick is fixed)

Measurement Chart.

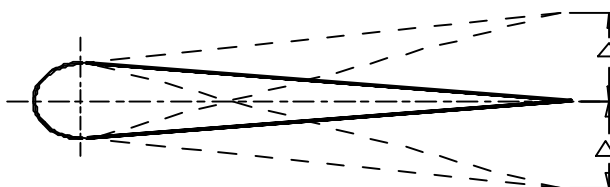

Table

<i>No.</i>	<i>Control surfaces</i>	<i>Tolerable deviations</i>
1.	Elevators	$\Delta = \pm 1\text{mm}$
2.	Ailerons	$\Delta = \pm 1.75\text{mm}$
3.	Flaps	$\Delta = \pm 1.5\text{mm}$

#### à) Elevator backlash elimination:

Elevator backlash is eliminated replacing pins LAK-12 34010113. After pins replacement "scissors" between rear edges of the elevator are permitted up to  $\Delta$  2mm (see drafts No.1, No.2)

# Draft No.1

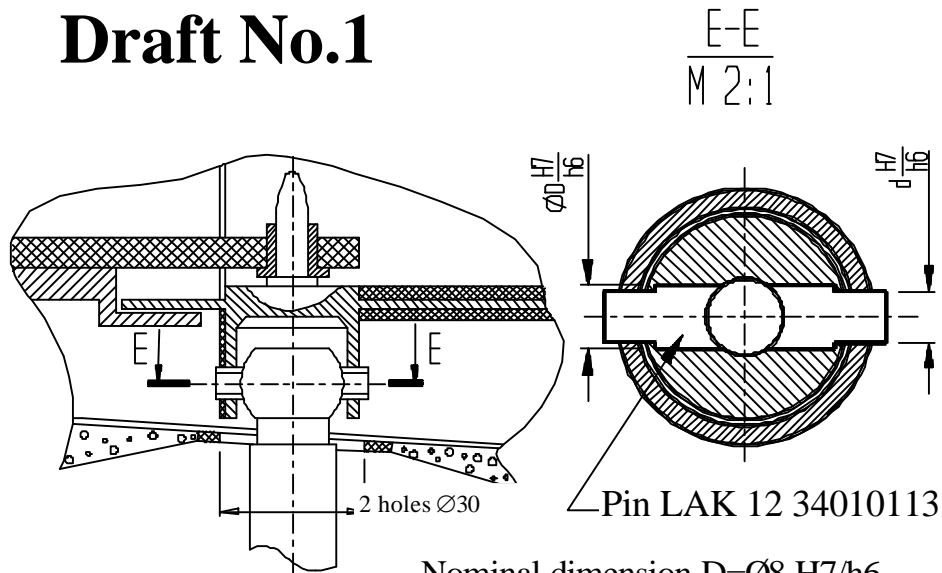

Nominal dimension  $D = \text{Ø}8 \text{ H7/h6}$

Repairing dimension No.1  $D = \text{Ø}8.1 \text{ H7/h6}$

No.2  $D = \text{Ø}8.2 \text{ H7/h6}$

Nominal dimension  $D = \text{Ø}6 \text{ H7/h6}$

Repairing dimension No.1  $D = \text{Ø}6.1 \text{ H7/h6}$

No.2  $D = \text{Ø}6.2 \text{ H7/h6}$

# Draft No.2

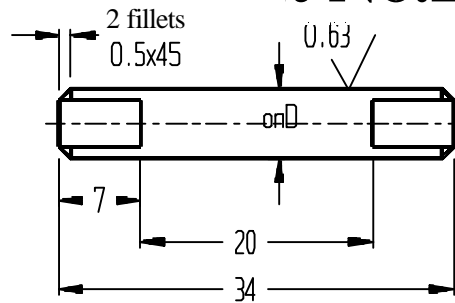

1. Rounded rod

1D ГОСТ2590-71  
30 VFGA ГОСТ4512-71

2. Thermal processing

$\sigma_b = 110 \pm 10 \text{ kGmm}^2$

3. Control group OST100021-72

5. Not indicated limit deviations of dimensions

.2

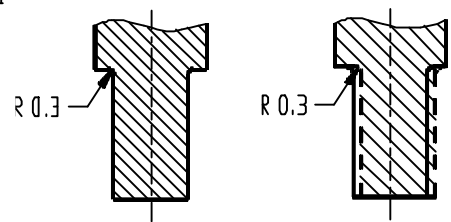
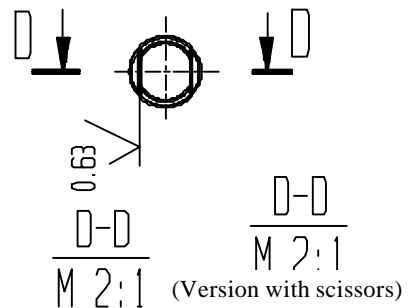

“Scissors” between elevators are eliminated using pin of special form (see draft No.2 version "scissors")

**b) Ailerons backlash elimination:**

Backlash in the aileron control attachment point is eliminated replacing spigots LAK-10A20500501 and fastening nuts 3373A-5 on the bracket of ailerons control attachment point.

**Draft No.3**

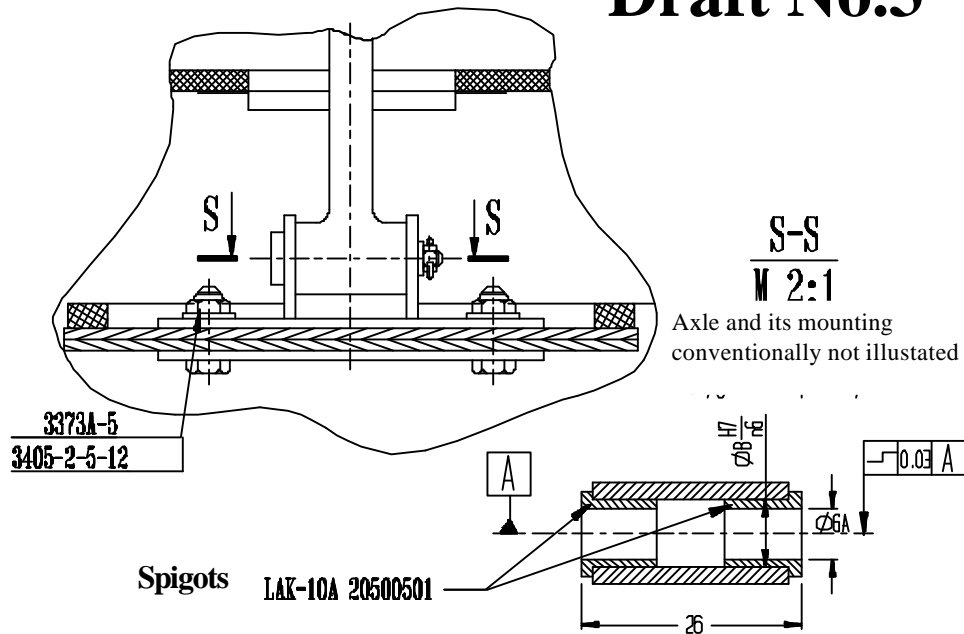

**Spigot LAK-10A20500501**

**1. Material**

**Draft No.4**

UNREPRODUCIBLE

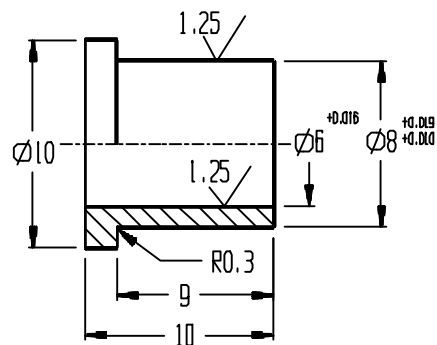

**c) Flaps backlash elimination:**

**DRAFT No.5**

ЗСКИЗ Nr. 5

**acing pin LAK-12 50001102**

B-B  
M 2:1

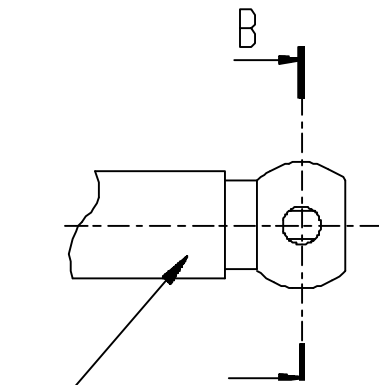

Flaps control shaft

Вал управления закрылками  
LAK-12 50001100M

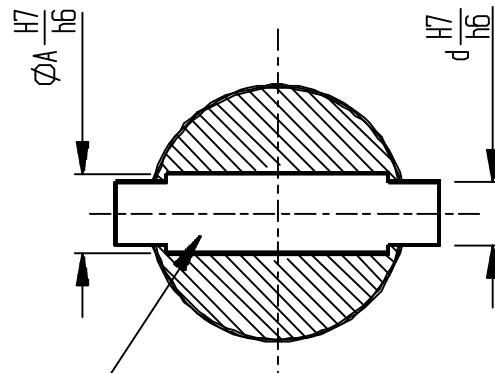

Pin

Палец LAK12 50001102

Nominal dimension A=Ø10 H7/ 6

Repairing dimension No.1 A=Ø10.1 H7/ 6

No.2 A=Ø10.2 H7/ 6

Nr.2 A=10.2 H7/h6

**DRAFT No.6**

ЗСКИЗ Nr. 6  
Pin

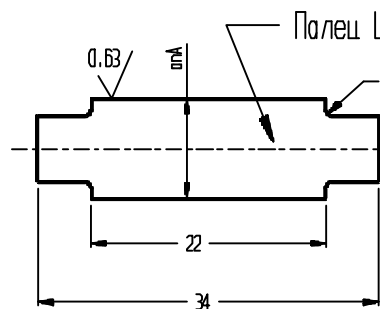

Палец LAK12 50001102

Nominal dimension D=6 H7/h6

Repairing dimension No.1 D=6.1 H7/h6

No.2 D=6.2 H7/h6

Nr.2 d=6.2 H7/h6

**1. Rounded rod**

**2. Thermal processing:  $\sigma_b=120\pm 10$  kG/mm<sup>2</sup>**

**2. Measure the backlash of control stick.**

Backlash of control stick is measured when the ailerons and elevators are fixed.

**Tolerances of backlash:**

a) when the elevator is fixed-  $\Delta = \pm 1.5\text{mm}$ .

b) when the ailerons are fixed-  $\Delta = \pm 1.5\text{mm}$ .

**Measurement Chart**

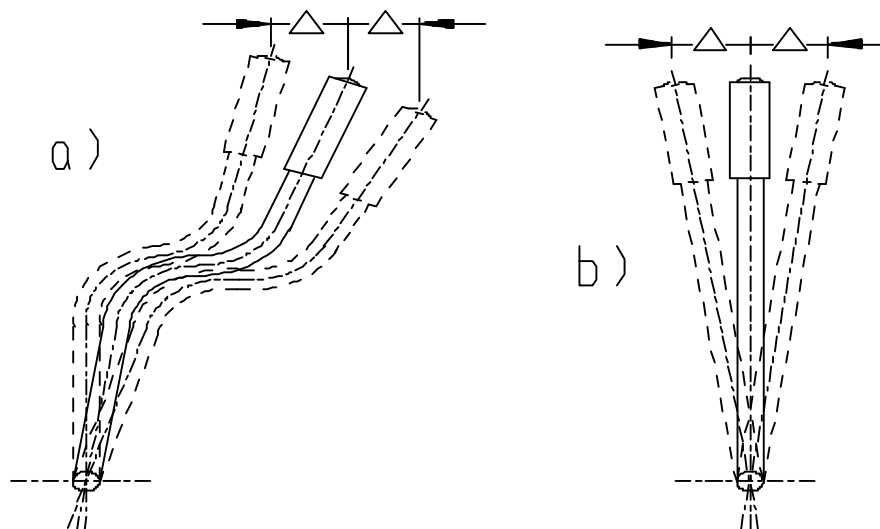

**3. Measure a backlash between fuselage and wing cantilevers:**

Backlash is measured in the attachment point of fuselage and wing cantilevers.

**Backlash tolerance-  $\Delta = 0.5\text{mm}$**

Backlash is eliminated putting in spigots (see draft No.8)

**Draft No.7**

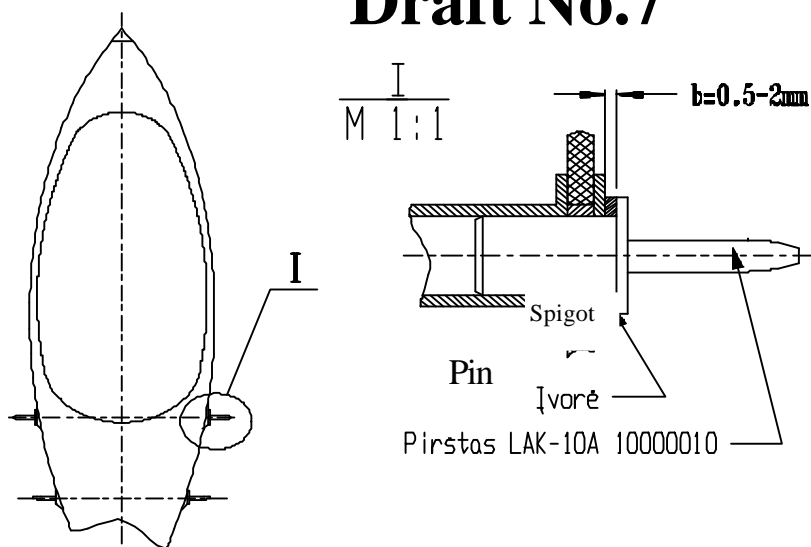

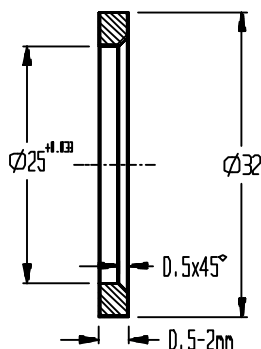
**Draft No.8****1. Material:****2. Coating: C6**

**3. Not indicated limit deviations of dimensions:**  
**Holes H14,**  
**Shafts h14**  
**The rest ±IT14/2**

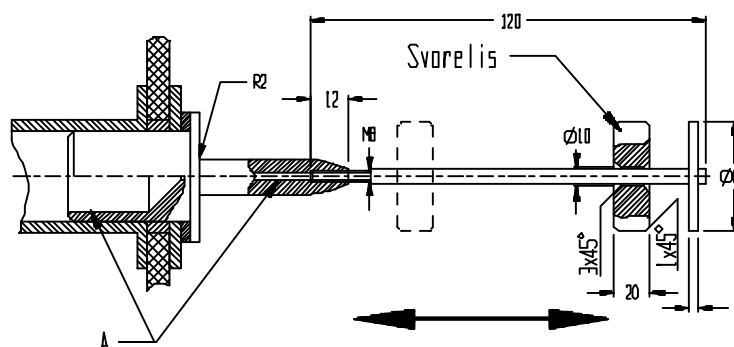
**SPIGOT:****Fuselage lateral pin removing draft;****Draft No.9** Little load

**Fuselage lateral pin is removed by gentle blows of a little load against the support plate (see draft No.9)**

**ATTENTION: After pin removal check the hole internal surface A. If the areas of corrosion found, grind the surface and prime.**

**4. Measure the transverse backlash of the stabilizer in respect to the fuselage. Backlash tolerance  $\Delta=4\text{mm}$ .**

**Stabilizer backlash is eliminated covering the stabilizer tube surface A with additional chrome layer (see draft No.11)**



<b>JSC SPORTINE AVIACIJA</b>	<b>Page 9</b>
<b>Bulletin No. 012.5.Re.001A</b>	<b>Total 9</b>

**7. Check the internal stabilizer ribs.**

**No cracks on the ribs surfaces are tolerable.**

**8. Check flaps and ailerons attachment brackets.**

**Lubricate axles. Replace worn pins.**

**9. Check board ribs of the wing cantilevers. No ribs damage or coming off the wing envelope is tolerable. No cracks on the external rings of brackets in the lateral attachment points of the wing cantilevers are tolerable.**

**10. Check the state of the cock and tubes in the water-ballast system. If the friction is great, disassemble and lubricate the cock. No cracks on tubes are tolerable.**

**11. Check the rods connection tips.**

**Press and release fixing device. It should return to the primary position.**

**12. Check the security of control rods.**

**No backlash of locking nuts is tolerable.**

**13. Check the metal surfaces of control rods.**

**If the areas of corrosion are found, grind them with fine glass-paper and prime.**

**14. Check the surfaces of tubes in the fuselage truss.**

**If the areas of corrosion are found, grind them with fine glass-paper and prime.**

**15. Check gear control system.**

**Detach wing cantilevers from the fuselage and put the aft part of the fuselage on a trestle. Clean gear control system from dirt and lubricate.**

**16. Check the release hook control system.**

**Clean the release hook from dirt and lubricate.**

**ATTENTION:**

**Any repair of metal attachment points and parts are only permitted after concordance with the factory.**