

JSC “SPORTINĖ AVIACIJA”	Page 3
Service Bulletin No. 019.8.Re.009A	Pages 4

1. Subject: Extension of the approved life time from 1500 flight hours to 3000 hrs.

The copies of the service bulletin No. 019.8.Re.009A are sent to:

1. Civil Aviation Administration of the Lithuanian Republic (CAA) – 1 copy;
2. EASA RP for LAK-19, LBA, Germany - 1 copy;
3. EASA, - 1 copy;
4. Aviation authorities of countries, which issued Type Certificates for the LAK-19, 1 copy;
5. For the known owners of the LAK-19 or administration of organizations (clubs) having LAK-19 gliders – 1 copy.

2. Affected:

Type: LAK-19

Manufacture: JSC “Sportinė Aviacija”, Pociūnai, LT-59327 Prienai, Lithuania.

Serial numbers affected: all serial numbers.

Original type certificate: EASA Type Certificate No.EASA.A.012 (5 August 2004).

3. Reason: possibility to extend the approved lifetime from 1500 flight hours to 3000 hrs.

4. Time of compliance: this service bulletin must be accomplished after 1500 flight hours of the sailplane.

5. Actions:

5.1 Replace in existing Sailplane Maintenance Manual:

1. List of Effective pages;
2. Record of revisions;
3. Pages: 5/8, 5/9, 5/10, 6/1.

5.2 Perform Inspection of the sailplane after every 1000 flight hours according requirements of the Maintenance Manual, section 5.7 (new pages).

6. Mass and balance: the described actions do not affect C.G of the glider. A new weight and C.G. determination is not necessary.

7. Documentation and materials: see Action.

New Maintenance Manual pages has to be ordered directly from the manufacture - JSC “Sportinė Aviacija”, Pociūnai, LT-59327 Prienai, Lithuania.

8. Accomplishment and log entry: Action to be accomplished by an approved service station and entered in sailplane log by licensed inspector.

JSC “SPORTINĒ AVIACIJA”	Page 4
Service Bulletin No. 019.8.Re.009A	Pages 4

Supplement: 6 pages according item 5.1 of this service bulletin No.019.8.Re.009A

14. To check surfaces of ends of wing spars (Fig.1), surfaces of external wing root ribs, paying special attention to connection zones of root ribs to spar ends and wing shells. If there are some splits or other damage on glass fiber reinforced plastics it is necessary to repair the damaged place.

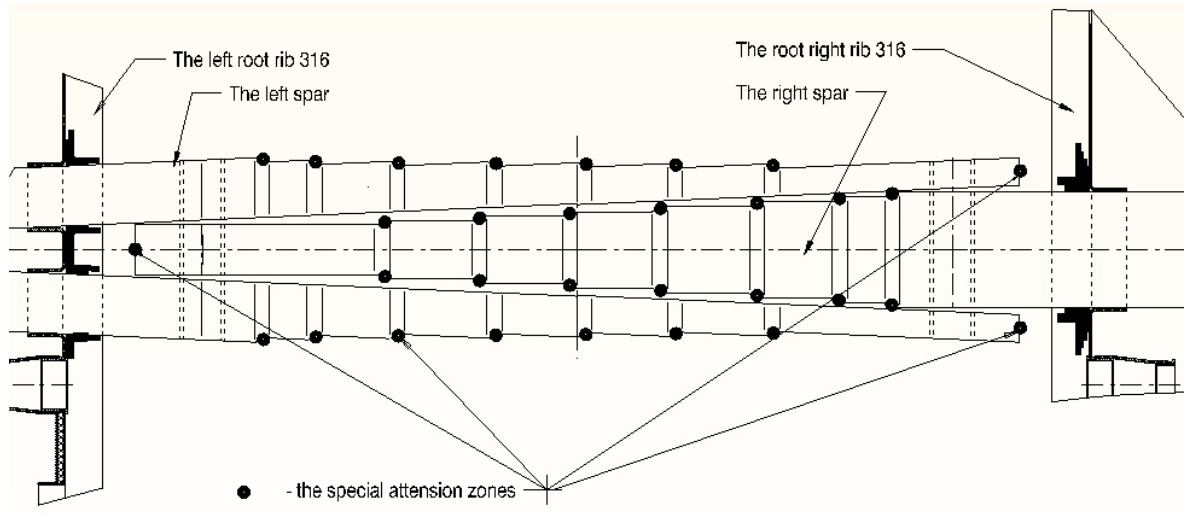
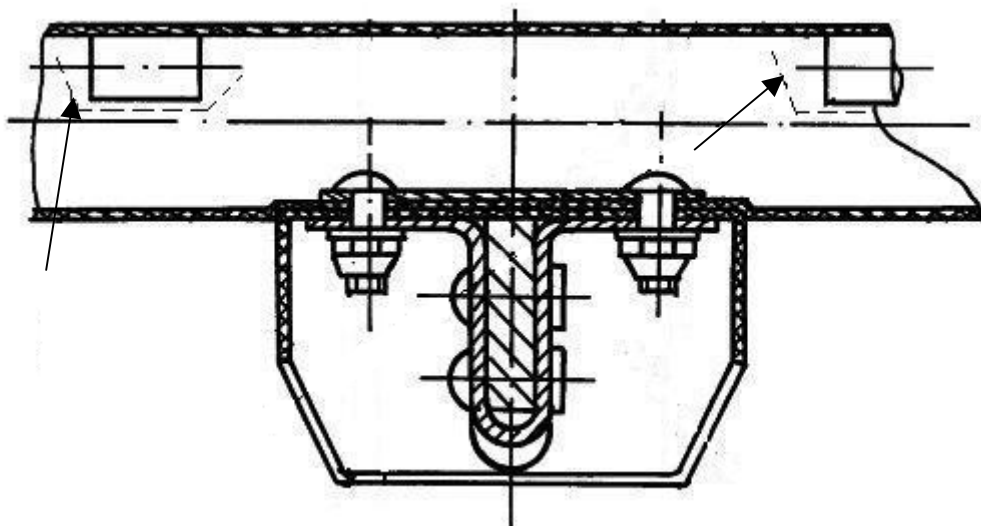

Fig.1. The wing spar.

15. To check external surfaces of wings, ailerons, flaps, fuselage, stabilizer, elevators and rudder. The special attention zones:

- a) the surfaces around hinge joints of control unit of elevators on the horizontal tail.



b) the glued zones of the vertical tail spar onto the upper fin part

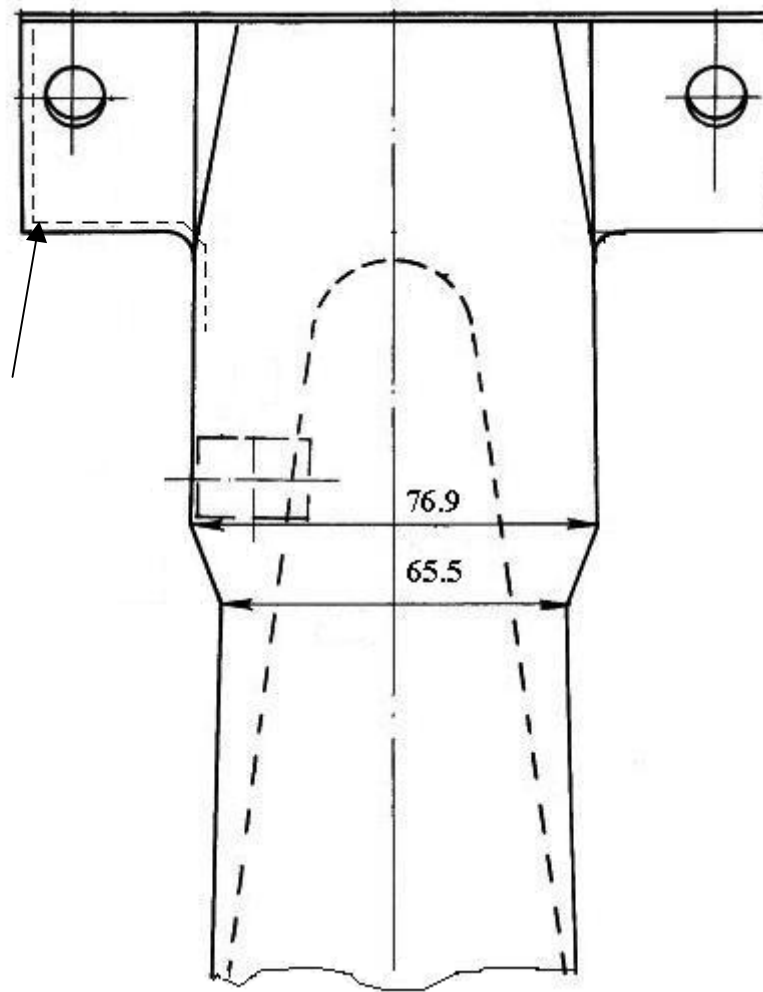

c) the elevator root rib

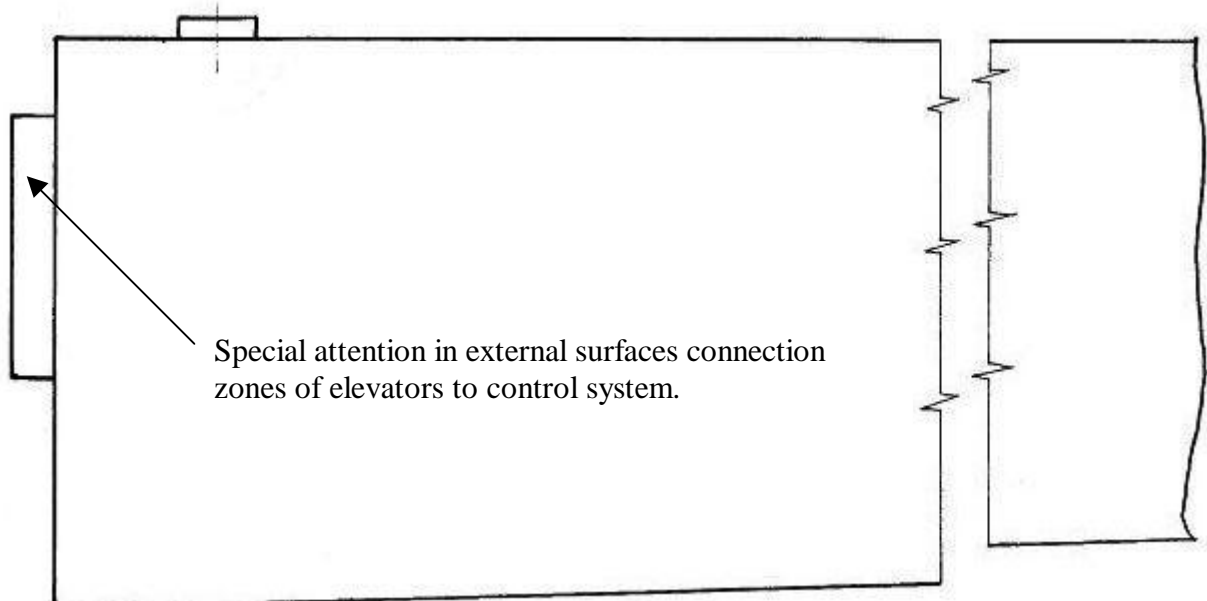

d) the fuselage bulkhead

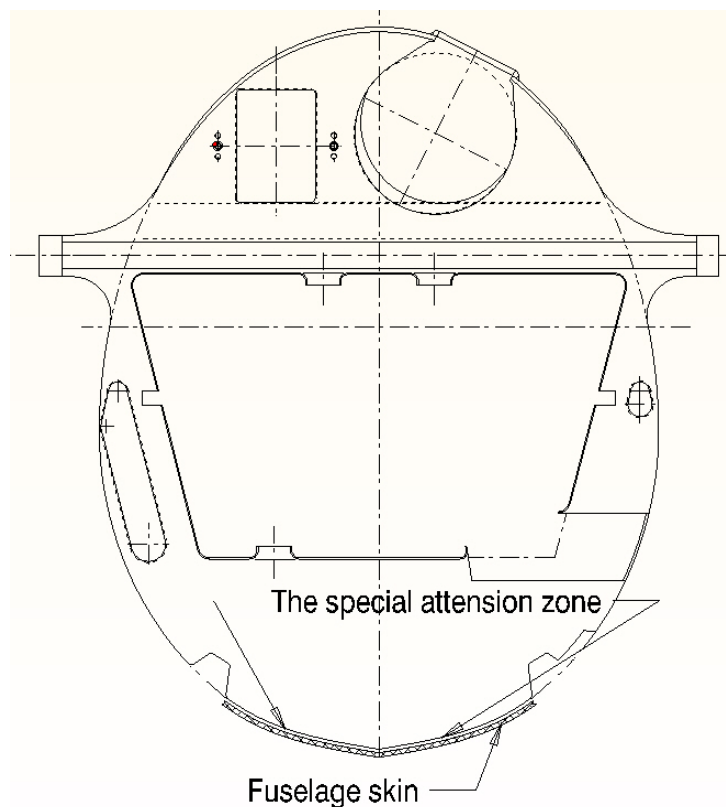

In zones where paint has cracks it is necessary to clean off the paint and check glass fiber reinforced plastic for cracks and if necessary to repair the damage.

Initial clean off of paint shall be done with glass-paper No 180, No 220 finishing with No 320 or even finer.

16. To check external surfaces of galvanized coating of metal parts. Zones with damaged protective galvanized or paint coating if they are not damaged by corrosion reducing strength may be repaired. After careful cleaning off of the surface with glass-paper till metallic glitter and its defatting protective prime and enamel layers are put on following manual and directions of producers of these coatings.

17. To check towing hook, sailplane instruments and additional equipment following corresponding guides of their factories-producers.

18. To check technical condition and tightness of connections of static and dynamic pressure pipes and moisture setting tanks.

19. To check technical condition of instrument markings and placards. Replace them if necessary.

20. Repair shall be done following guides given in Section 8 of this Manual. If damaged isn't included in it repair shall be done according to recommendations of manufacturer of the sailplane.

21. To check water ballast tanks in wings and fin for hermeticallity.

22. After doing all the works the sailplane shall be weighed and C.G. shall be defined.

SECTION 6

The sailplane life limits

The approved life limits of the sailplane LAK-19 is:

- lifetime 6000 flight hours if only aero towing is used;
- lifetime 3000 flight hours if winch-launching is used;

The continued airworthiness of the sailplane is ensured by prescribed inspections and technical maintenance works done during its using :

- 1) annual sailplane inspection before starting the flight season according to requirements of Section 5 of "Maintenance Manual";
- 2) daily (before every flight day) and preflight sailplane inspection according to requirements of Section 4 of "Flight Manual" and Section 3 of "Maintenance Manual";
- 3) special sailplane inspection after a rough landings, ground loops, exceeding of allowed loadings and etc. according to requirements of section 5 of "Maintenance Manual";
- 4) inspection and works according to requirements of bulletins issued for the sailplane;
- 5) inspection and works according to requirements of maintenance documents (Section 4 of "Maintenance Manual") of parts with limited lifetime (towing hook, safety belts, instruments and others);
- 6) inspection after every 1000 flight hours according to requirements of Section 5 of "Maintenance Manual";

Checking of a sailplane, maintenance and necessary repair works shall be done just by qualified staff having permission to those works.

In the case of damages of the sailplane construction not included in the "Maintenance Manual" the repair shall be agreed with the manufacturer of the sailplane.